

REVISION RECORD				
REV	ECD	DESCRIPTION	DRFT	CHKD

NOTES:

MATERIAL:

- 1. HOUSING MATERIAL : GLASS FILLED POLYESTER UL94V-0.
- 2. CONTACT MATERIAL : PHOSPHOR BRONZE t=0.35mm.
- 3. PLATING : GOLD PLATING 3u"~50u" OVER NICKEL

ELECTRICAL:

- 1. VOLTAGE RATING : 125 VAC RMS.
- 2. CURRENT RATING : 1.5 AMP.
- 3. CONTACT RESISTANCE : 30 MILLIOHMS MAX.
- 4. INSULATION RESISTANCE : 500 MEGOHMS MIN @ 500V DC .
- 5. DIELECTRIC WITHSTANDING RESISTANCE : 1000V AC RMS 50Hz. 1MIN.

MECHANICAL:

- 1. DURRABILITY: : 750 CYCLES MIN.
- 2. PCB RETENTION PRE-SOLDER : 1 LB MIN.

ENVIRONMENTAL:

- 1. STORAGE : -40° C TO 85° C.
- 2. OPERATION : 0° C TO 70° C.

PART NUMBER:

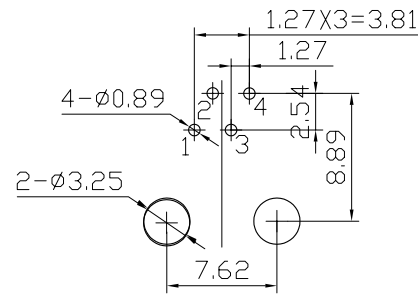
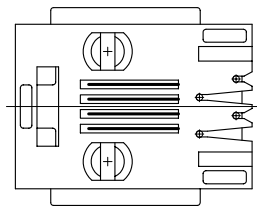
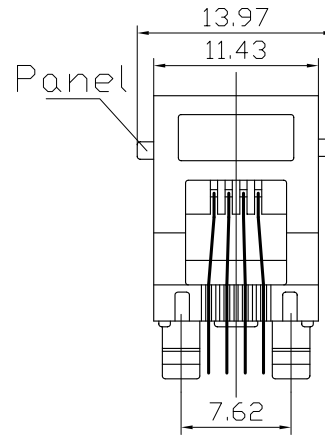
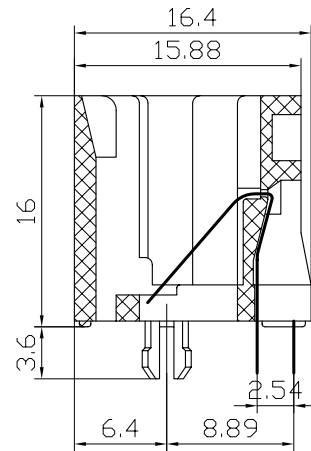
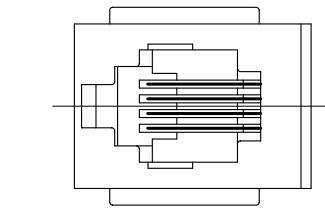

PC Board Layout
Component Side Shown

DETACHED LISTS	MM (INCH)		DFTO: SHB	DATE: 7.05.05	Coorle 库乐科技	
	TOLERANCES EXCEPT AS NOTED		CHKD: LANBO	DATE: 2007.05.05		
	MM		MFO:	DATE:	TITLE 52 TOP ENRYR JACK 4P4C	
	.0 ± 0.15	±	APPVL:	DATE:		
.00 ± 0.075	±	MATERIAL :		DRAWING NO. TE52A1003		
.000 ± 0.05	±	FINISH :				SIZE A3
ANGLES ± 0.5		QT'Y :		DRAWING NO. TE52A1003		
THIRD ANGLE PROJECTION		SCALE :				/PART NO.
				DD NOT SCALE DRAWING		
				SHEET OF		

H
G
F
E
D
C
B
A